

Fitting Instructions

Code: 50-4468

Front Strut Brace

These instructions are to be used in conjunction with Workshop manual.

Application:

- Holden Commodore VE 2006-on
 - Holden Statesman (Chevrolet Caprice) WM 2006-on
 - Chevrolet Lumina / Pontiac G8 VE 2006-on
- Always refer to current catalogue for complete application listing.

Contents

- 1 x complete strut tower assembly
- 1 x spacer packet;
 - 4 x large wedge spacers
 - 8 x small wedge spacers
- 1 x fastener packet;
 - 2 x M8 x 40mm bolts
 - 4 x M8 x 35mm bolts
 - 6 x M8 nyloc nuts
 - 6 x M8 flat washers

Installation guide:

Please read complete installation guide and check kit components prior to fitment. It is recommended that all work to be carried out by a qualified technician.

1. Remove end brackets from alloy centre bar.
2. Place small spacers in the top of the outside holes, and mark drilling positions as shown in Fig 1.
3. Place end brackets on top of strut towers, and mark drilling positions as per Fig 2, and centre punch as per Fig 3.

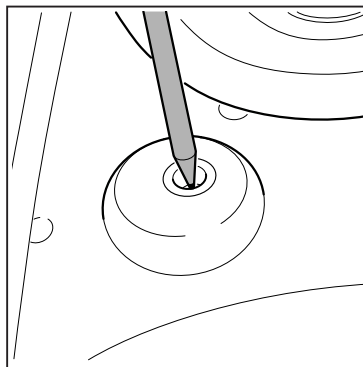

Fig 1.

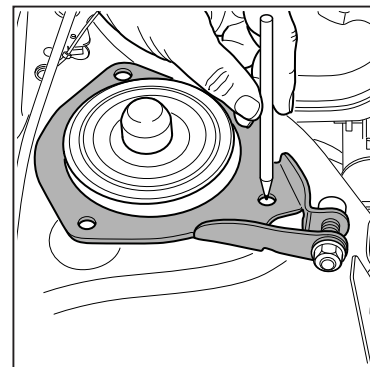

Fig 2.

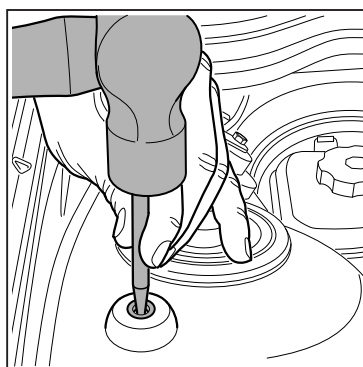

Fig 3.

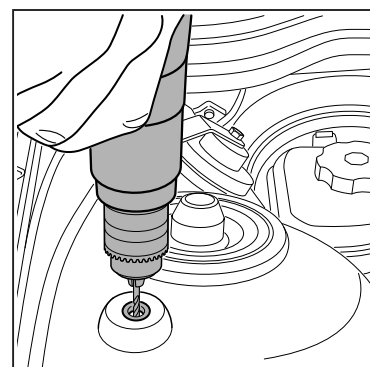

Fig 4.

4. Remove strut top thrust washers (large washer with rubber lip).
5. Raise the front of the car until wheels just clear the ground so that the struts drop below strut towers.

Support vehicle with appropriate safety chassis stands before continuing.

6. Drill 3 x Ø8mm clearance holes in each strut tower as shown in Fig 4.
7. Fit end brackets and loosely bolt to strut towers using hardware supplied.

Note: Use M8x40mm bolts with large spacers for the inside hole and M8x35mm bolts with small spacers for the outside holes as shown in Fig 5. Refer to Fig 7 for correct spacer assembly.

8. Adjust alloy strut bar to length and loosely fit to end brackets.
9. Tighten end bracket to strut tower mounting bolts to recommended torque setting of 20Nm.
10. Carefully lower the vehicle ensuring that strut top mounts correctly re-seat. Refit original top thrust washer and strut top nut, and torque to manufacturer's specifications.
11. Re-adjust alloy strut top bar to length and fit to the end brackets.

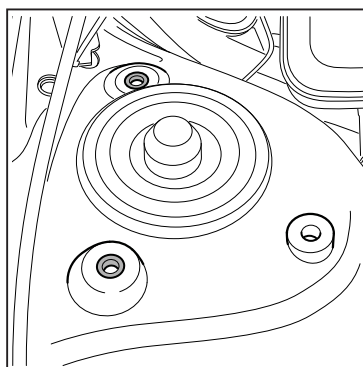

Fig 5.

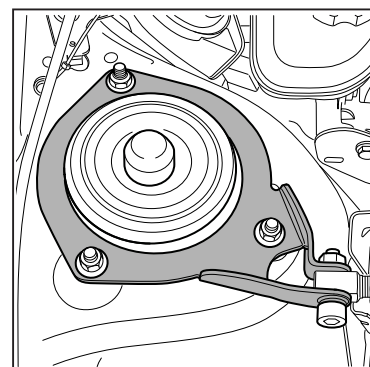

Fig 6.

Note: Adjustment provided is to be used for ease of fitment. Do not use the adjustment to pre-load the strut brace.

12. Check alloy strut bar alignment and engine and bonnet clearance - end bracket slotted mounting holes allow for minor height adjustment. Tighten all fittings to lock in position.
13. Check wheel alignment and adjust if required.
14. Check and re-tension all fittings again after a 100kms but no more than 200kms.

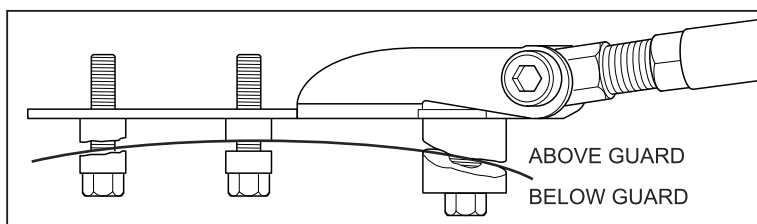

Fig 7.

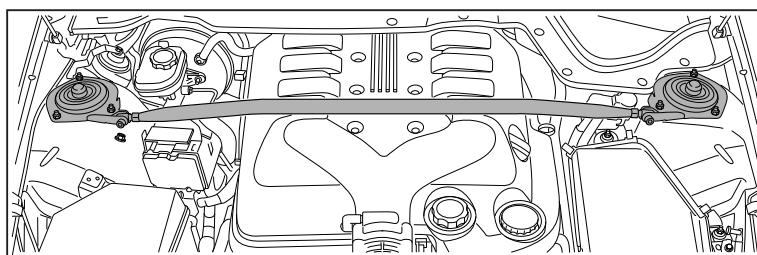

Fig 8.

NB: It is recommended that a licenced workshop or trades person carry out the above procedure and that workshop manual procedures are followed in addition to the above.