

Installation Guide

Steering Bump Steer Correction

Suits: VW Golf MK V Series

Z 5028

(Always refer to the current catalogue for complete application listings)

N.B: This installation guide should be used in conjunction with the workshop manual.

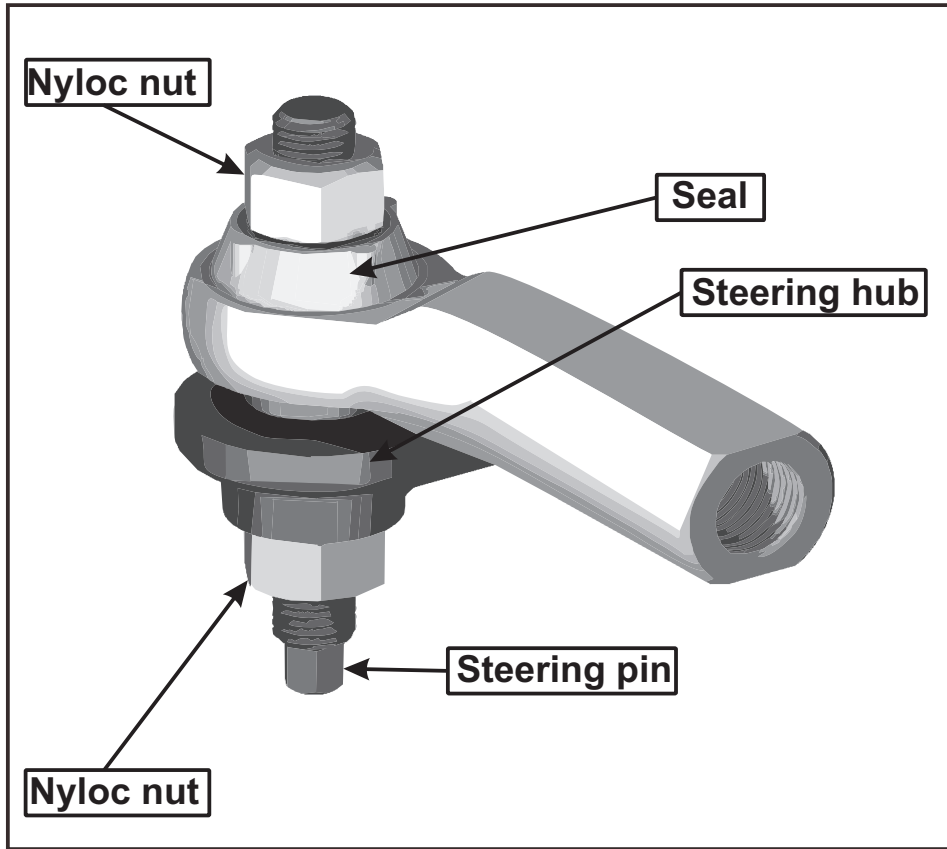

- Ensure the tie rod end is fitted around the correct way as the oe rod end was removed.
- Please note the rod ends are not side specific, and can be fitted on either side of the vehicle.
- It is recommended that a small amount of grease is supplied to the underside of the seal.
- Torque Nyloc nuts to manufacturers torque specifications.
- Carry out wheel alignment on completion of fitment.

N.B: It is recommended that a licenced workshop or trades person carry out the above procedure and that workshop manual and relevant safety procedures are followed in addition to the above.

Installation Guide

Steering Bump Steer Correction

Suits: VW Golf MK V Series

Z 5028

(Always refer to the current catalogue for complete application listings)

N.B: This installation guide should be used in conjunction with the workshop manual.

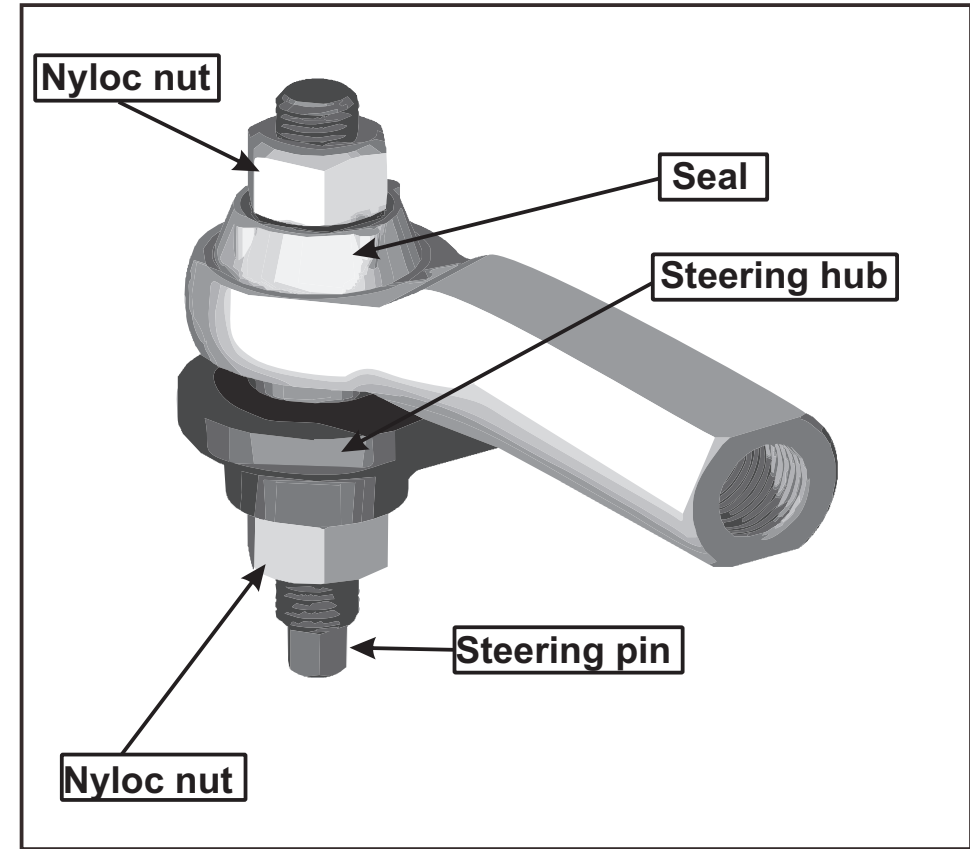

- Ensure the tie rod end is fitted around the correct way as the oe rod end was removed.
- Please note the rod ends are not side specific, and can be fitted on either side of the vehicle.
- It is recommended that a small amount of grease is supplied to the underside of the seal.
- Torque Nyloc nuts to manufacturers torque specifications.
- Carry out wheel alignment on completion of fitment.

N.B: It is recommended that a licenced workshop or trades person carry out the above procedure and that workshop manual and relevant safety procedures are followed in addition to the above.